



Vibration Monitoring Unit Series HE205

MADE IN
GERMANY

SIL2 **PL-d**



IECEE EAC



Segurança
INMETRO OCP 0029



IECEX UKCA

Proc. Cont. Eq.
for Ord. Loc.
Proc. Cont. Eq.
for Haz. Loc.



- Vibration acceleration (g rms)
- ATEX / IECEx / UKEx Zones 2/22 and 1/21
- cULus OrdLoc / HazLoc Div 2
- 2 potential-free switching contacts (Window function)
- Analogue current output: 4–20 mA
- Frequency range: 10 Hz – 1000 Hz
1 Hz – 1000 Hz



Date of manufacture: _____

Type description: _____

Serial no.: _____

Operating instructions

Vibration Monitoring Unit Type HE205

Standard and ATEX / IECEx / UKEx

Version: 2023-01-09

Attention!

Prior to commissioning the product, the instruction manual must be read and understood.

All rights reserved, including rights to translation.
Subject to modifications.

Please contact the company with any questions:

HAUBER-Elektronik GmbH

Fabrikstraße 6

D-72622 Nürtingen

Germany

Tel.: +49 (0) 7022 / 21750-0

Fax: +49 (0) 7022 / 21750-50

info@hauber-elektronik.de

www.hauber-elektronik.de

1 Contents

1	Contents.....	3
2	Safety information	5
3	Scope of this instruction manual	6
4	Vibration monitoring HE205	6
5	Intended Use.....	6
6	Scope of supply	6
7	Documents and Certificates.....	7
8	Transfer of liability when operating in potentially explosive atmospheres.....	7
9	Overview of application areas.....	8
10	Example labels.....	9
11	Information on the cULus validity range	10
12	Functional safety instructions	11
12.1	Safety level / key indicators	11
12.2	General notes	11
12.3	Instructions for the Fail Safe State.....	11
13	Technical data.....	12
13.1	General data	12
13.2	Electrical data	12
13.3	Typical frequency response.....	13
13.4	Properties of the integrated cable.....	14
13.5	Mechanical data.....	14
13.6	Housing dimensions.....	15
14	Connection.....	16
15	Functional description.....	17
15.1	Operating conditions.....	17
15.2	Alarm and limit setting	18
15.3	Limit values and delay times.....	19
16	Assembly and disassembly.....	20
16.1	General notes	20
16.2	Fixing the vibration monitoring unit to the mounting surface	20
16.3	Variant HE205.02 (Zone 2 / 22).....	21
16.4	Tamper protection.....	22
17	Installation and commissioning.....	23
17.1	General notes	23
17.2	Earthing concept.....	23
18	Maintenance and repair	24
18.1	General notes	24
18.2	Troubleshooting Table	24
19	Transport, storage and disposal	25
20	Coding HE205.....	26

21 EU and UK Declaration of Conformity27

2 Safety information

2.1 General

The safety instructions are intended to protect people and property from damage and hazards that could arise as the result of improper use, incorrect operation or other misuse or devices, especially in explosive areas. Therefore, please read the operating instructions carefully before working on the product or operating it. The operating instructions must be accessible to operating personnel at all times.

Please make sure that all documents are present and complete before commissioning or performing other work on the product. If the documents have not all been delivered in full or if further copies are necessary, they can also be obtained in other languages.

The product is built according to the latest state of the art. However, hazards to people, machinery and systems can still arise as the result of improper handling, unintended use or operation and maintenance by persons inadequately trained on the product.

All those who are involved in the installation, operation and maintenance of the product in the operator's plant must read and understand the operating instructions.

The product may only be assembled, disassembled, installed and repaired by instructed, sufficiently trained and authorised personnel.

2.2 Symbols used



This symbol indicates an explosion hazard.



This symbol indicates a hazard from electrical current.



This symbol indicates safety-related information.



This symbol indicates information unrelated to safety.

3 Scope of this instruction manual

This instruction manual for the HE205-type vibration monitoring unit applies to the following versions:

HE205.00, HE205.01 and HE205.02

The variants are functionally identical. The variants HE205.01 and HE205.02 have additional certifications and labels which permit use in potentially explosive atmospheres. For further information, see chapter "Overview of application areas" on page 8.

4 Vibration monitoring HE205

The HE205 type vibration monitoring unit is used to measure and monitor the vibration acceleration of machinery. It offers the following features:

- Two limit values and associated delay timings can be adjusted separately.
- The two potential-free switching contacts will signal any exceeding of the relevant defined limit values. This can be used to generate an alarm.
- Measurement parameter: vibration acceleration (g rms).
- Analogue current output: Interference-free DC signal from 4-20 mA, proportional to the measuring range of the monitoring unit.
- A break on the monitoring cable can be detected by the subsequent evaluation device: DC signal value < 3.5 mA.

5 Intended Use

The HE205 is used to protect machines and mechanical equipment against undue strong vibrations. It may only be used in accordance with the specifications listed in the data sheet. It is used exclusively for measuring mechanical vibrations.

Main fields of application: Conveyors, screening equipment, drying and cooling equipment and similar oscillating mechanical equipment.



If the equipment is used in a manner not specified by the manufacturer, the protection provided by the equipment may be impaired.

6 Scope of supply

All versions include:

- Vibration monitoring
- Cylinder head screw with hex socket, M8 x 20 mm
- Seal label
- Operating instructions

7 Documents and Certificates

You can find the following documents and certificates for HE205 type at www.hauber-elektro-nik.de where they can be viewed and downloaded:

- EU type examination certificate ATEX Zone 1 / 21, no.: UL 20 ATEX 2421 X Rev. 0
- Type examination certificate ATEX Zone 2 / 22, no.: UL 21 ATEX 2570 X
- IECEx certificate of conformity, no.: IECEx ULD 20.0022X
- UL certificate of conformity, no.: E507077-20210204
- UKEx certificate number: UL22UKEX2479X
- UKEx certificate number: UL22UKEX2480X
- EAC Declaration
- Functional safety certificate (SIL 2)
- Safety manual SIL2

8 Transfer of liability when operating in potentially explosive atmospheres

The owner of the system is exclusively liable for the appropriate configuration of the electrical connections with respect to explosion protection regulations and correct commissioning.

If the system is installed by a sub-contractor on behalf of the owner, the system may only be commissioned after the sub-contractor has issued written confirmation in the form of a certificate of installation that the system has been installed correctly and professionally in accordance with the applicable legal regulations.

The operator is obliged to notify the responsible authorities of the initial commissioning of explosion-protected systems or system components and their re-commissioning following extensive changes or maintenance.

9 Overview of application areas

Coding		HE205.00.xx.xx.00.xxx	HE205.00.xx.xx.01.xxx	HE205.02.xx.xx.00.xxx	HE205.02.xx.xx.01.xxx	HE205.01.xx.xx.00.xxx	HE205.01.xx.xx.02.xxx
Connection	M12 connector	x		x			
	Integrated cable		x		x	x	x
Measuring head temperature T _M Ambient temperature T _A	-40 °C ≤ T _M ≤ 85 °C -40 °C ≤ T _A ≤ 60 °C	x		x		x	
	Restriction for the range of application cULus: -30 °C ≤ T _M ≤ 80 °C -30 °C ≤ T _A ≤ 60 °C			x	x		
	-20 °C ≤ T _M ≤ 125 °C -20 °C ≤ T _A ≤ 60 °C						x

Standard		x	x	x	x	x	x
	Proc. Cont. Eq. Ord. Loc E507077	x	x	x	x		

Ex Zone 2 and 22	II 3G Ex ec IIC T4 Gc II 3D Ex tc IIIC 135°C Dc	UL 21 ATEX 2570 X			x	x	
	Ex ec IIC T4 Gc Ex tc IIIC 135°C Dc	IECEX ULD 20.0022 Issue 0X			x	x	
	II 3G Ex ec IIC T4 Gc II 3D Ex tc IIIC 135°C Dc	UL22UKEX2480X			x	x	
	Proc. Cont. Eq. Haz. Loc. Class I, Division 2, Groups A, B, C and D, T4 Class II, Division 2 Groups F and G, T4	E516625			x	x	
	Ex ec IIC T4 Gc Ex tc IIIC 135°C Dc	UL-BR 21.1250X			x	x	
	Ex nA IIC T4 Gc Ex tD A22 IP66/67 T135°C	No: 2021122315114599			x	x	

Ex Zone 1 and 21	II 2G Ex db IIC T4 Gb II 2D Ex tb IIIC 135°C Db	UL 20 ATEX 2421 X				x	x
	Ex db IIC T4 Gb Ex tb IIIC 135°C Db	IECEX ULD 20.0022 Issue 0X				x	x
	II 2G Ex db IIC T4 Gb II 2D Ex tb IIIC 135°C Db	UL22UKEX2479X				x	x
	Ex db IIC T4 Gb Ex tb IIIC 135°C Db	UL-BR 21.1250X				x	x
	Ex d IIC T4 Gb Ex tD A21 IP66/67 T135°C	No: 2021122315114599				x	x

10 Example labels

Variant 1 - HE205.00.xx.xx.xx.00.000

 Type: HE2xx.00.xx.xx.xx.00.000 Item-no.: 12345 Serial-no.: 123456 / 2023 Measuring range v_{eff} : 0...xx mm/s Frequency range v_{eff} : xx...xxxx Hz $-40^{\circ}\text{C} \leq T_{amb} \leq +60^{\circ}\text{C}$ Ver.: 1.1	MADE IN GERMANY	IEC	 LISTED E507077 Proc. Cont. Eq. Ord. Loc.	 UK CA	Manufacturer: Hauber-Elektronik GmbH Fabrikstraße 6 72622 Nürtingen Germany www.hauber-elektronik.de
	 TUV SUD	 CE	 LISTED E507077 Proc. Cont. Eq. Ord. Loc.	 LISTED E507077 Proc. Cont. Eq. Ord. Loc.	
	 SIL2 PL-d	 LISTED E507077 Proc. Cont. Eq. Ord. Loc.	 LISTED E507077 Proc. Cont. Eq. Ord. Loc.	 LISTED E507077 Proc. Cont. Eq. Ord. Loc.	
	IP 66/67 Type 4x Enclosure			 LISTED E507077 Proc. Cont. Eq. Ord. Loc.	

Variant 2 - HE205.00.xx.xx.xx.01.xxx

 Type: HE2xx.00.xx.xx.xx.01.xxx Item-no.: 12345 Serial-no.: 123456 / 2023 Measuring range v_{eff} : 0...xx mm/s Frequency range v_{eff} : xx...xxxx Hz $-35^{\circ}\text{C} \leq T_{amb} \leq +60^{\circ}\text{C}$ Ver.: 1.1	MADE IN GERMANY	IEC	 LISTED E507077 Proc. Cont. Eq. Ord. Loc.	 UK CA	Manufacturer: Hauber-Elektronik GmbH Fabrikstraße 6 72622 Nürtingen Germany www.hauber-elektronik.de
	 TUV SUD	 CE	 LISTED E507077 Proc. Cont. Eq. Ord. Loc.	 LISTED E507077 Proc. Cont. Eq. Ord. Loc.	
	 SIL2 PL-d	 LISTED E507077 Proc. Cont. Eq. Ord. Loc.	 LISTED E507077 Proc. Cont. Eq. Ord. Loc.	 LISTED E507077 Proc. Cont. Eq. Ord. Loc.	
	IP 66/67 Type 4x Enclosure			 LISTED E507077 Proc. Cont. Eq. Ord. Loc.	

Variant 3 - HE205.02.xx.xx.xx.00.000

 Type: HE2xx.02.xx.xx.xx.00.000 Item-no.: 12345 Serial-no.: 123456 / 2023 Measuring range v_{eff} : 0...xx mm/s Frequency range v_{eff} : xx...xxxx Hz $-40^{\circ}\text{C} \leq T_{amb} \leq +60^{\circ}\text{C}$ Ver.: 1.1	MADE IN GERMANY	IECEx	 LISTED ES16625 Proc. Cont. Eq. Haz. Loc.	 LISTED ES16625 Proc. Cont. Eq. Haz. Loc.	Manufacturer: Hauber-Elektronik GmbH Fabrikstraße 6 72622 Nürtingen Germany www.hauber-elektronik.de
	 TUV SUD	 CE	 LISTED ES16625 Proc. Cont. Eq. Haz. Loc.	 LISTED ES16625 Proc. Cont. Eq. Haz. Loc.	
	 SIL2 PL-d	 LISTED ES16625 Proc. Cont. Eq. Haz. Loc.	 LISTED ES16625 Proc. Cont. Eq. Haz. Loc.	 LISTED ES16625 Proc. Cont. Eq. Haz. Loc.	
	IP 66/67 Type 4x Enclosure			 LISTED ES16625 Proc. Cont. Eq. Haz. Loc.	

Variant 4 - HE205.02.xx.xx.xx.01.xxx

 Type: HE2xx.02.xx.xx.xx.01.xxx Item-no.: 12345 Serial-no.: 123456 / 2023 Measuring range v_{eff} : 0...xx mm/s Frequency range v_{eff} : xx...xxxx Hz $-35^{\circ}\text{C} \leq T_{amb} \leq +60^{\circ}\text{C}$ Ver.: 1.1	MADE IN GERMANY	IECEx	 LISTED ES16625 Proc. Cont. Eq. Haz. Loc.	 LISTED ES16625 Proc. Cont. Eq. Haz. Loc.	Manufacturer: Hauber-Elektronik GmbH Fabrikstraße 6 72622 Nürtingen Germany www.hauber-elektronik.de
	 TUV SUD	 CE	 LISTED ES16625 Proc. Cont. Eq. Haz. Loc.	 LISTED ES16625 Proc. Cont. Eq. Haz. Loc.	
	 SIL2 PL-d	 LISTED ES16625 Proc. Cont. Eq. Haz. Loc.	 LISTED ES16625 Proc. Cont. Eq. Haz. Loc.	 LISTED ES16625 Proc. Cont. Eq. Haz. Loc.	
	IP 66/67 Type 4x Enclosure			 LISTED ES16625 Proc. Cont. Eq. Haz. Loc.	

Variant 5 - HE205.01.xx.xx.xx.00.xxx

 Type: HE2xx.01.xx.xx.xx.00.xxx Item-no.: 12345 Serial-no.: 123456 / 2023 Measuring range v_{eff} : 0...xx mm/s Frequency range v_{eff} : xx...xxxx Hz $-40^{\circ}\text{C} \leq T_{amb} \leq +60^{\circ}\text{C}$ Ver.: 1.1	MADE IN GERMANY	IECEx	 LISTED ES16625 Proc. Cont. Eq. Haz. Loc.	 LISTED ES16625 Proc. Cont. Eq. Haz. Loc.	Manufacturer: Hauber-Elektronik GmbH Fabrikstraße 6 72622 Nürtingen Germany www.hauber-elektronik.de
	 TUV SUD	 CE	 LISTED ES16625 Proc. Cont. Eq. Haz. Loc.	 LISTED ES16625 Proc. Cont. Eq. Haz. Loc.	
	 SIL2 PL-d	 LISTED ES16625 Proc. Cont. Eq. Haz. Loc.	 LISTED ES16625 Proc. Cont. Eq. Haz. Loc.	 LISTED ES16625 Proc. Cont. Eq. Haz. Loc.	
	IP 66/67 Type 4x Enclosure			 LISTED ES16625 Proc. Cont. Eq. Haz. Loc.	

Variant 6 - HE205.01.xx.xx.xx.02.xxx

 Type: HE2xx.01.xx.xx.xx.02.xxx Item-no.: 12345 Serial-no.: 123456 / 2023 Measuring range v_{eff} : 0...xx mm/s Frequency range v_{eff} : xx...xxxx Hz $-20^{\circ}\text{C} \leq T_{amb} \leq +60^{\circ}\text{C}$ Ver.: 1.1	MADE IN GERMANY	IECEx	 LISTED ES16625 Proc. Cont. Eq. Haz. Loc.	 LISTED ES16625 Proc. Cont. Eq. Haz. Loc.	Manufacturer: Hauber-Elektronik GmbH Fabrikstraße 6 72622 Nürtingen Germany www.hauber-elektronik.de
	 TUV SUD	 CE	 LISTED ES16625 Proc. Cont. Eq. Haz. Loc.	 LISTED ES16625 Proc. Cont. Eq. Haz. Loc.	
	 SIL2 PL-d	 LISTED ES16625 Proc. Cont. Eq. Haz. Loc.	 LISTED ES16625 Proc. Cont. Eq. Haz. Loc.	 LISTED ES16625 Proc. Cont. Eq. Haz. Loc.	
	IP 66/67 Type 4x Enclosure			 LISTED ES16625 Proc. Cont. Eq. Haz. Loc.	

11 Information on the cULus validity range

In order to install the device according to the UL/CSA/IEC standard, the following information must be observed.

Electrical protection



Devices must be protected by means of fuses, circuit breakers, overheating protection, impedance-limiting switches or similar to ensure protection against excessive power output if there is a fault in the device. Protection must be applied to supply lines and switching lines.



A circuit breaker suitable for 30V/3A according to UL Standard 489/CSA Standard (C22.2) no. 5/IEC 60947-2 must be installed near the device.



A fuse suitable according to UL Standard 248/CSA Standard (C22.2) no. 248/IEC 60127 must be installed near the device. The fuse must have a slow triggering characteristic ("T").

Limited temperature range

The following temperature ranges apply for variants with integrated cable:

Measuring head temperature	$-30\text{ °C} \leq T_M \leq +80\text{ °C}$
Ambient temperature	$-30\text{ °C} \leq T_{Amb} \leq +60\text{ °C}$

12 Functional safety instructions

12.1 Safety level / key indicators

The HE205 vibration monitoring hardware was tested by TÜV Süd. The results meet the criteria according to SIL2 and PI-d.

MTTF	984,898 hours = 112.43 years
DC _{avg}	>90%
MTTF _d	2,889,526 hours = 329.85 years = HIGH
CCF	95 (fulfilled)

Further key indicators and information can be found in the safety manual

12.2 General notes



A reboot of the vibration monitoring unit must be performed annually in order to test the switching of potential-free switching contacts.



While the sensor is in configuration mode, the safety functions are deactivated.

12.3 Instructions for the Fail Safe State

When the power supply is switched on, the vibration monitoring unit will perform a self-test. During operation, self-tests are performed automatically in cycles. If a self-test fails, the vibration monitoring unit switches to the Fail Safe State. In the Fail Safe State all status LEDs are lit, all potential-free switching contacts are open and the analogue current output supplies 0 mA.

13 Technical data

13.1 General data



Each sensor has one of the listed measuring and frequency ranges. Further ranges on request.

Please indicate the measuring and frequency range in your request.

Measuring range:	0 – 1 g rms 0 – 2 g rms 0 – 4 g rms 0 – 6 g rms 0 – 8 g rms 0 –10 g rms
Measuring accuracy:	± 10% (as per DIN ISO 2954)
Transverse sensitivity:	< 5%
Frequency range:	10 Hz...1000 Hz (standard) 1 Hz...1000 Hz
Calibration point:	159.2 Hz and 90% amplitude of measuring range
Readiness delay:	10 sec Seconds
Maximum acceleration:	±16.5 g
Lifetime:	10 years

Tab. 1: General data

13.2 Electrical data

Output signal:	1 x 4-20 mA (proportional to the measuring range)
Switching contact:	2 x potential-free switching contacts (pre- and main alarm)
Switching contact switching load:	1A / 30 V DC
Power supply:	24 V DC ± 10%
Power input (max.):	100 mA
Load/output load (max.):	500 Ω
Automatic:	As soon as the vibration values fall below the limit values, the potential-free switching contacts automatically re-energize.

Tab. 2: Electrical data

13.3 Typical frequency response

10 Hz–1,000 Hz (standard)

The frequency response is recorded using a reference sensor.

- 4 Hz . . . 1200 Hz acceleration sensor

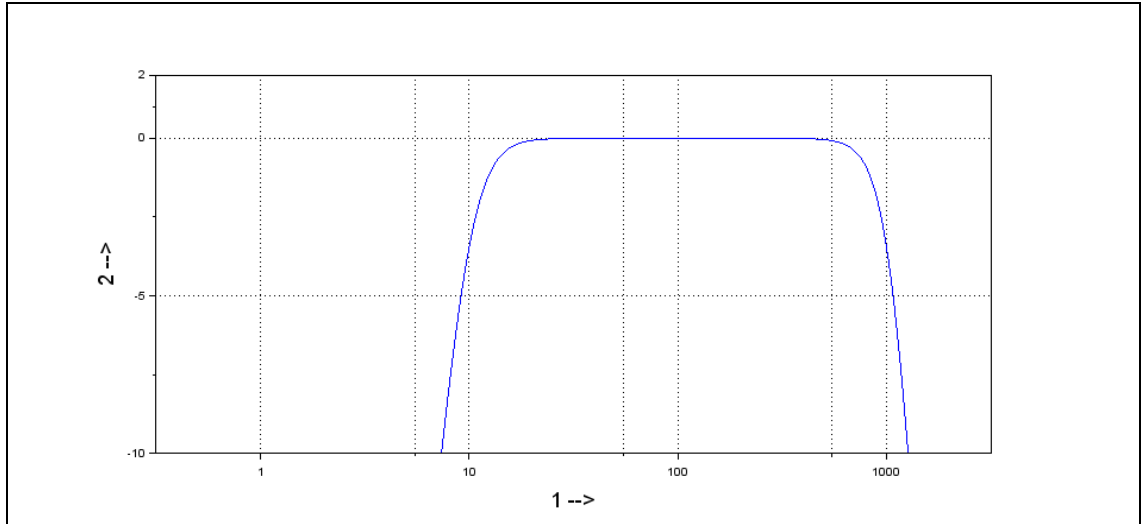

Fig. 1: Typical frequency response 10 Hz–1000 Hz

- 1 Frequency in Hz
- 2 Amplification in dB

1 Hz–1000 Hz

The frequency response is recorded using two reference sensors.

- 1 Hz . . . 10 Hz laser sensor
- 10 Hz . . . 1200 Hz acceleration sensor

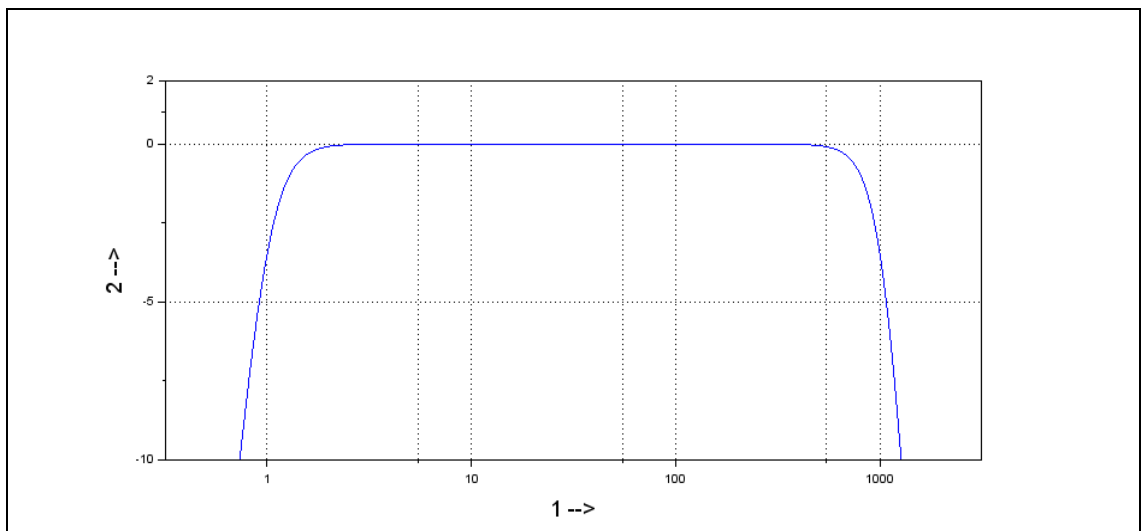

Fig. 2: Typical frequency response 1 Hz–1000 Hz

- 1 Frequency in Hz
- 2 Amplification in dB

13.4 Properties of the integrated cable

Cable type	Li9YC11Y 8x0.25 mm ²
Conductor material	E-Cu stranded wire
Conductor insulation	PP 9Y
Coating	PUR 11Y Etherbase
Coating diameter	6.0 ± 0.2 mm
Temperature range	-40 °C ... +90 °C fixed -20 °C ... +90 °C moving
Minimum bending radius	30 mm fixed 60 mm moving
Flame resistant	Yes, according to UL FT2
Halogen-free	Yes, according to VDE 0472 Part 815

Tab. 3: Technical data of the integrated cable

13.5 Mechanical data



Additional materials can be found in section "Coding" on page 26.

Housing material:	Stainless steel V2A, material no.: 1.4305 (standard)
Fastening:	Cylinder head Allen screw M8 x 20 mm Thread pitch: 1.25 mm (standard)
Mounting:	Housing must be earthed via the M8 fastening
Cover tightening torque:	5 Nm
Measuring direction:	Along the fastening axis
Weight:	approx. 500 g
Protection class:	Cover and plug connection closed: IP 66/67 Type 4X enclosure Product is suitable for outdoor use
Max. humidity:	100%

Tab. 4: Mechanical data

13.6 Housing dimensions

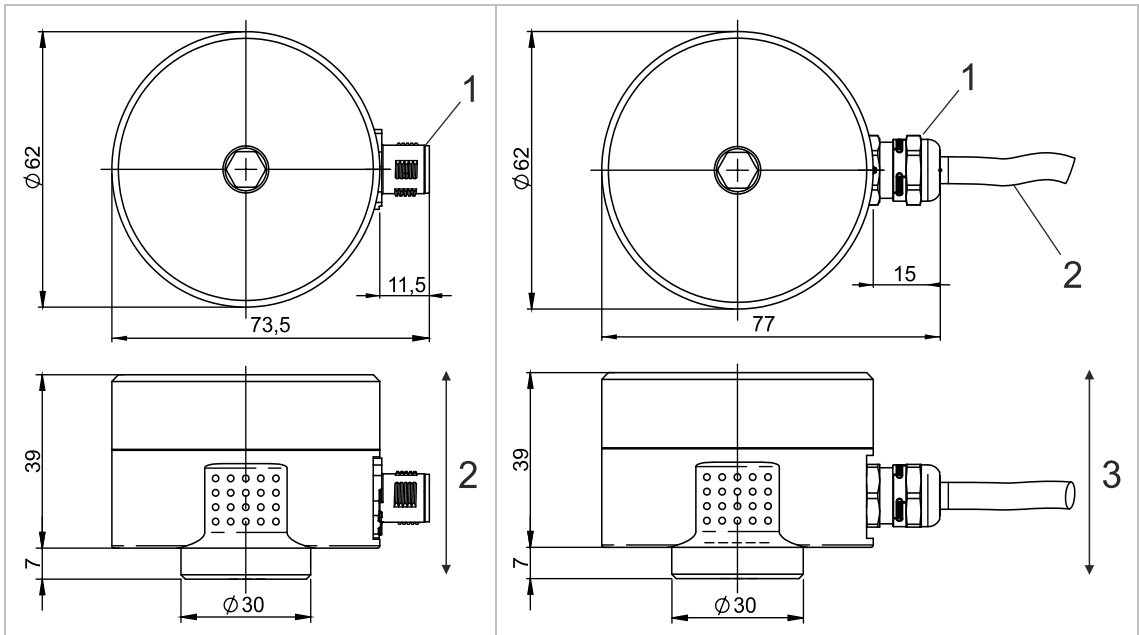
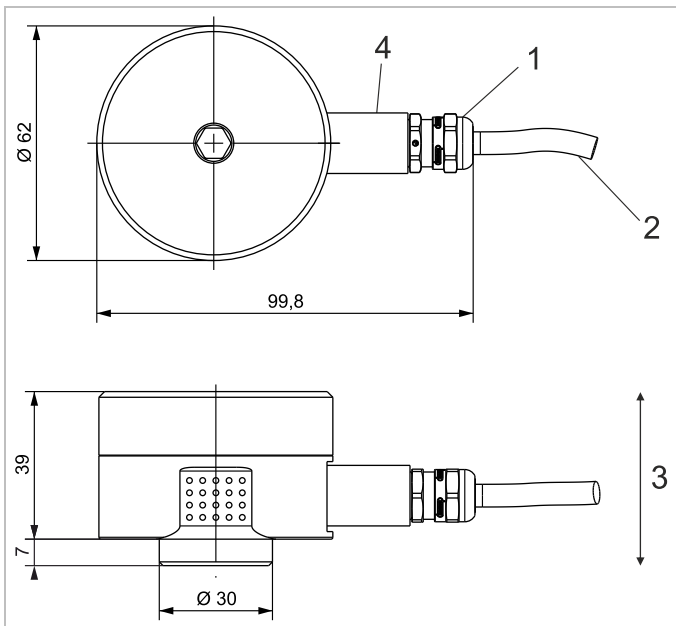

Fig. 3: Housing with M12 connector

Fig. 4: Housing with integrated cable

- 1 M12 connector
- 2 Measuring direction

- 1 Cable gland
- 2 Connecting cable
- 3 Measuring direction



All measurements in mm

Fig. 5: Housing with integrated cable and clamping sleeve base for metal protection hose

- 1 Cable gland
- 2 Connecting cable
- 3 Measuring direction
- 4 Clamping sleeve base for metal protection hose

14 Connection

Version:	M12 connector		
		Pin 1:	24 V DC
		Pin 2:	GND
		Pin 3:	4-20 mA output signal
		Pin 4:	NC (Not connected)
		Pin 5:	Potential-free switching contact 1 +
		Pin 6:	Potential-free switching contact 1 -
		Pin 7:	Potential-free switching contact 2 +
		Pin 8:	Potential-free switching contact 2 -
Version:	Integrated cable		
		Pin 1:	white 24 V DC
		Pin 2:	brown GND
		Pin 3:	green 4-20 mA output signal
		Pin 4:	yellow NC (Not connected)
		Pin 5:	grey Potential-free switching contact 1 +
		Pin 6:	pink Potential-free switching contact 1 -
		Pin 7:	blue Potential-free switching contact 2 +
		Pin 8:	red Potential-free switching contact 2 -
Wiring diagram:			

Fig. 6: Wiring diagram

- 1 Potential-free switching contact 1 (pin 5: + , Pin 6: -)
- 2 Potential-free switching contact 2 (pin 7: + , Pin 8: -)
- 3 Evaluation unit

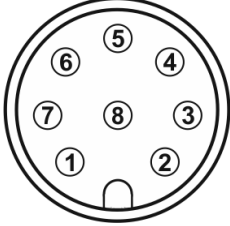
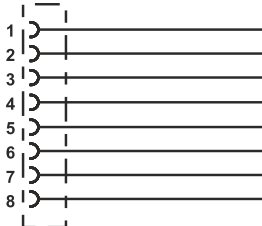

The wiring diagram shows the alarm status or the current status!
Potential-free switching contacts 1 and 2 are open.

15 Functional description



In an explosive atmosphere the vibration monitoring unit HE205 will only be opened in a de-energized state.

The type HE205 is used for monitoring vibration acceleration. If the acceleration value is below or above the adjustable window area, an alarm will be triggered. The vibration monitoring unit contains two channels independent from each other, LIM1 and LIM2. The lower limit value of the window area is adjusted on LIM1 and the upper limit value is adjusted on LIM2 (see chart). The HE205 type also has an analogue current output. This supplies direct current of 4-20 mA proportional to the vibration amplitude.

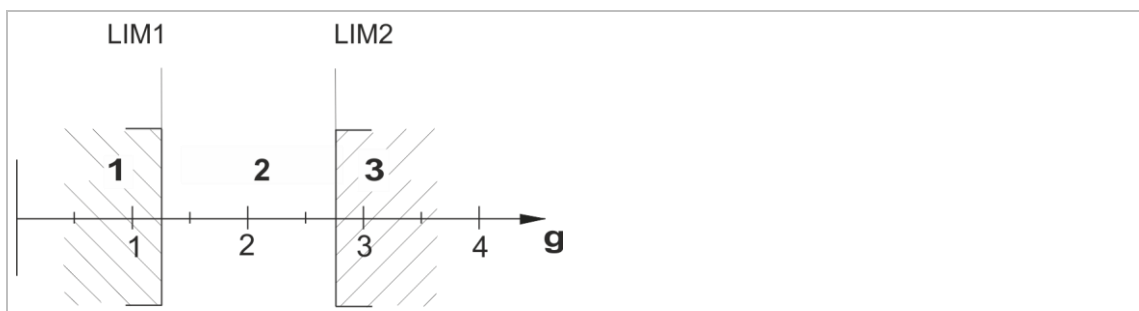

Fig. 7: Window function

- 1 Alarm for values below LIM1
- 2 Window area
- 3 Alarm for values above LIM2

15.1 Operating conditions

Operating state	Reading	Switching contacts	LED status
OK	Within limit values	Closed	green
WARNING	Outside of limit values, delay time runs	Closed	green + yellow
ALARM	Outside of limit values, delay time expired	Open	red
Fail Safe State	0 mA	Open	red + yellow + green
De-energized	0 mA	Open	All LEDs off

Tab. 5: Operating conditions

15.2 Alarm and limit setting



While the sensor is in configuration mode, the safety functions are deactivated.

By pressing the "Save Config" button, the current configuration is displayed by the LEDs around the HEX switches. For further information, see chapter "Limit values and delay times" on page 19.

The limit values and delay times are calibrated using the respective HEX switch. As soon as a switch position is changed, all LEDs start flashing. Press and hold the "Save Config" button for three seconds to save the configuration. Acceptance of the configuration is signalled by steady lighting up of the LEDs in the selected HEX switch position.

The configuration can only be accepted if $LIM1 \leq LIM2$.

After about five minutes the LEDs turn off automatically.

15.3 Limit values and delay times

SET-Position ↓	Limit values (g)					
Measuring range →	0-1 g	0-2 g	0-4 g	0-6 g	0-8 g	0-10 g
0	0	0	0	0	0	0
1	0.063	0.125	0.25	0.375	0.5	0.625
2	0.125	0.25	0.5	0.75	1	1.25
3	0.188	0.375	0.75	1.125	1.5	1.875
4	0.25	0.5	1	1.5	2	2.5
5	0.313	0.625	1.25	1.875	2.5	3.125
6	0.375	0.75	1.5	2.25	3	3.75
7	0.438	0.875	1.75	2.625	3.5	4.375
8	0.5	1	2	3	4	5
9	0.563	1.125	2.25	3.375	4.5	5.625
10	0.625	1.25	2.5	3.75	5	6.25
11	0.688	1.375	2.75	4.125	5.5	6.875
12	0.75	1.5	3	4.5	6	7.5
13	0.813	1.625	3.25	4.875	6.5	8.125
14	0.875	1.75	3.5	5.25	7	8.75
15	0.938	1.875	3.75	5.625	7.5	9.375

Tab. 6: Limit values

The **SET rotary button** has 16 positions, representing the limit value of an alarm. The measuring range of the vibration monitoring unit is divided into 16 linear steps.

In general: $Limit\ value = \frac{Upper\ limit\ measuring\ range}{16} \times SET\ rotary\ button\ position$

Example: Limit setting

Measuring range: 0–4 g
 SET rotary button Pos.: 8 (9)
 Limit value: 2 g (2.25 g)

Delay times

TIME Position	0	1	2	3	4	5	6	7	8	9	10	11	12	13	14	15
Delay time (secs)	0	1	2	3	4	5	7.5	10	12.5	15	17.5	20	25	30	45	60

Tab. 7: Delay times

16 Assembly and disassembly

16.1 General notes

Assembly and disassembly work on and with the monitoring unit may only be performed by an authorised specialist familiar with the safety regulations governing handling electrical components! When using EX-certified monitoring units in potentially explosive atmospheres, the professional must also be familiar with the relevant safety regulations!



Before assembly and disassembly disconnect the monitoring unit from the power supply! Separate plug connections must always be de-energized! If EX-certified monitoring is operated in a potentially explosive atmosphere, there is otherwise an explosion hazard, due to spark formation!



The monitoring unit housing must be earthed via the fastening - through the machine earth of the mounting surface or through a separate protective conductor (PE)!

16.2 Fixing the vibration monitoring unit to the mounting surface

Prerequisites

- Mounting surface is clean and flat; i.e. free of paint, rust, etc.
- Threaded hole in mounting surface:
15 mm, M8

Tools and material

- Hex socket key SW 6, SW 8
- Torque wrench SW 6, SW 8
- Cylinder head screw with hex socket M8x20
- Spring washers for M8

Work steps and instructions

- Unscrew housing cover from housing base; hex socket key SW 8
- Attach monitoring unit using cylinder head screws and spring washers with 8 Nm on mounting surface; Torque wrench SW 6
- Screw the housing cover back onto the housing base and tighten to 5 Nm; Torque wrench SW 8

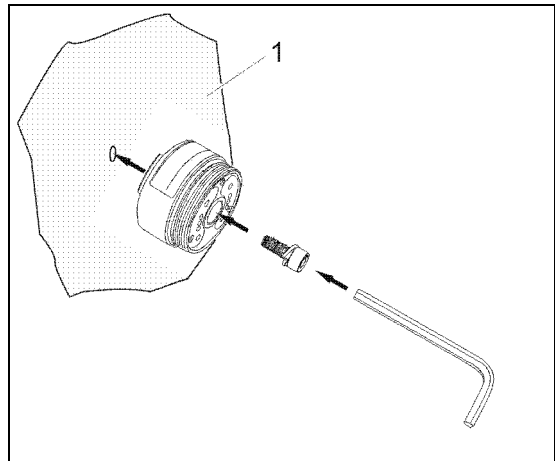

Fastening on mounting surface (1)

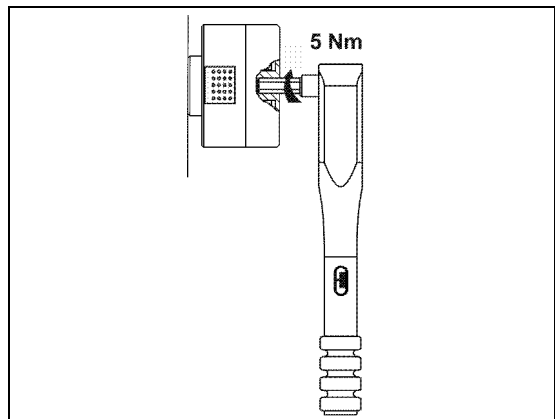

Tighten housing cover with torque wrench (2)



In order to avoid cold welding of the housing cover to the housing base, the thread is treated ex-works with an assembly paste for stainless steel connections.

16.3 Variant HE205.02 (Zone 2 / 22)



The Zone 2/22 variant may not be operated without the safety clip to guard against accidental disconnection of the plug connection! If operated in a potentially explosive atmosphere, there is otherwise an explosion hazard, due to spark formation!

16.3.1 Attaching the safety clip

1. Insert the connecting cable socket into the M12 connector as far as it will go (mind the position of the code cam).
2. Tighten the knurled rotating ring of the socket by hand.
3. Attach the safety clip to guard against accidental disconnection of the plug connection.
 - Place both shell halves of the clip around the plug connection.
 - Press both shell halves firmly together with your hands until the lock snaps into place.
 - Place the arrow connected to the two shell halves around the cable and pull it through the eyelet at the other end so that the notice "DO NOT DISCONNECT UNDER VOLTAGE" can be read alongside the cable.

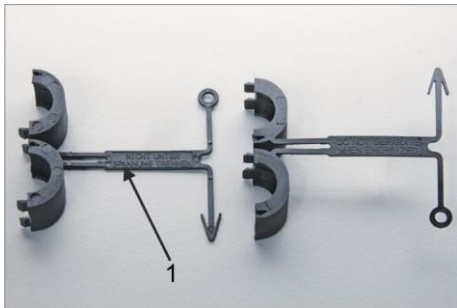

Fig. 8: Safety clip

1 Notice

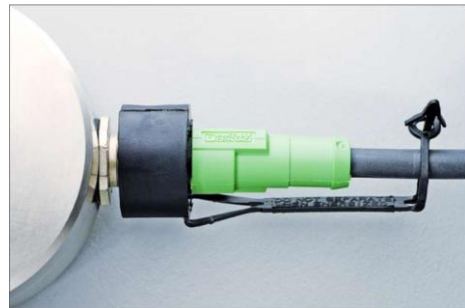

Fig. 9: Attached safety clip

16.3.2 Attaching the protection cap

After disconnecting the plug, the protection cap must be attached to the M12 plug!
Detach the safety clip and attach the protection cap.

1. Disconnect voltage.
2. Pry apart both shell halves of the sleeve with a screwdriver.
3. Close off the M12 plug well with the protection cap.

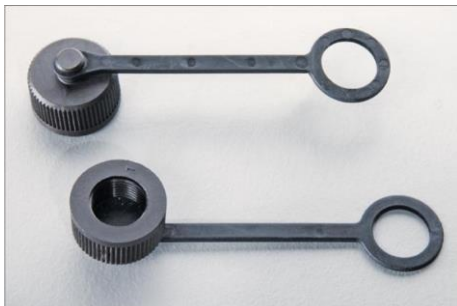

Fig. 10: Protection cap



Fig. 11: Attached protection cap

16.4 Tamper protection

Attach seal labels

The "SEALED" seal label reveals any unauthorised opening of the housing cover.

After installation of the housing cover by the system operator, the seal label shall be attached to the side above the housing joint.

If any tampering is attempted, the seal label is destroyed and the tampering will be visible to the system operator.

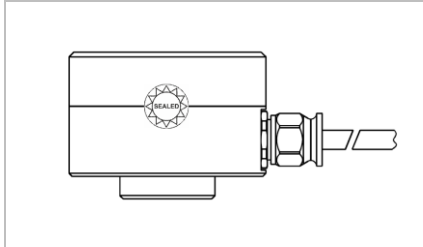

Fig. 12: Seal label

17 Installation and commissioning

17.1 General notes

Installation and commissioning of the vibration monitoring unit may only be performed by an authorised specialist familiar with the safety regulations governing handling electrical components. When installing and commissioning EX-certified monitoring units in potentially explosive atmospheres, the professional must also be familiar with the relevant safety regulations!



The commissioning will only be carried out with the housing cover correctly screwed on (tightening torque = 5 Nm)! If EX-certified monitoring is operated in a potentially explosive atmosphere, there is otherwise an explosion hazard, due to spark formation!



Protect the connection cable and any extension cable from electrical interference and mechanical damage! Local regulations and instructions must be observed in doing so!

17.2 Earthing concept

The earthing concept stipulates that the sensor cable shield is electrically connected to the sensor housing through the knurled nut and is at earth potential on the evaluation unit or the switch cabinet. For longer wires, we recommend separating the disconnecting the shield at the evaluation unit (4) to prevent compensating currents through the shield.

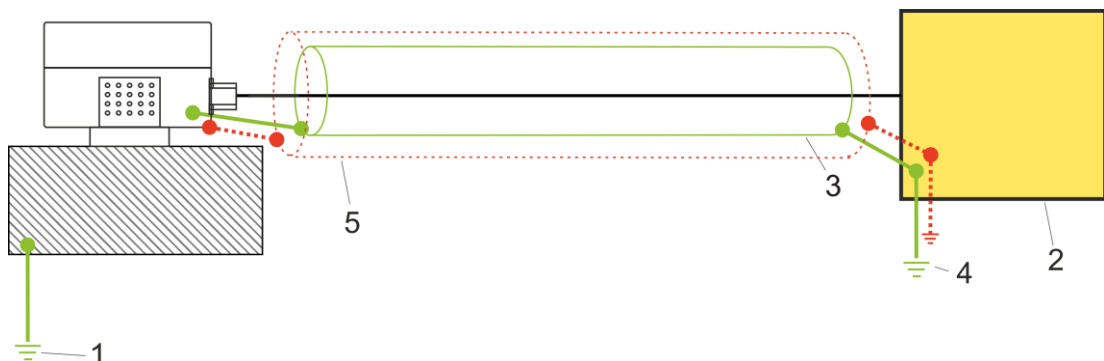

Fig. 13: Earthing concept HE205

- 1 Machine earth
- 2 Evaluation unit (measuring instrument, SPS, ...)
- 3 Cable shield
- 4 Evaluation unit earth potential
- 5 Optional flexible metal tubing (only available for version with integrated cable)

18 Maintenance and repair

18.1 General notes



Repair and cleaning work on vibration monitoring units may only be performed by an authorised specialist familiar with the safety regulations governing handling electrical components.



Before repair and cleaning disconnect the monitoring unit from the power supply! Separate plug connections must always be de-energized!



Immediately replace defective connection cables!
A defective vibration monitoring unit must be completely replaced!



The vibration monitoring unit HE205 is maintenance-free!

18.2 Troubleshooting Table

Fault	Cause	Action
No measured value (4-20 mA)	No power supply	Check power source and/or supply
	Discontinuity in connecting cable	Replace connecting cable
	Fuse defective	Replace fuse
	Connection has incorrect polarity	Connection of correct pole
	Vibration monitoring unit faulty	Vibration Monitoring Unit replace
Switching contact doesn't switch	Wrong limit value set	Set correct limit value
	No power supply	Check power source and/or supply
	Discontinuity in connection	Replace connecting cable
	Fuse defective	Replace fuse
	Connection has incorrect polarity	Connection of correct pole
	Defective monitoring unit	Replace monitoring unit
False reading	Vibration monitoring unit not mounted in a friction-locked manner	Mount vibration monitoring unit in a friction-locked manner
	Vibration monitoring unit installed in wrong place	Install vibration monitoring unit in correct place
	EMC problems	Siehe "Earthing concept" on page 23.

Tab. 8: Troubleshooting Table

19 Transport, storage and disposal

The sensor must be protected from damaging environmental factors and mechanical damage during transport with the use of adequate packing.

The sensor may not be stored in ambient temperatures outside the permitted operating temperature.

The product contains electronic components and must be disposed of properly in accordance with local laws and regulations.

20 Coding HE205

HE205.	00.	2g.	01.	00.	00.	000
--------	-----	-----	-----	-----	-----	-----

HE series

205 = Monitoring SIL2
 4-20 mA ~ g rms
 free limit values
 (Window function)

ATEX / IECEx / UKEx

00 = no ATEX / IECEx / UKEx
 01 = ATEX / IECEx / UKEx (Zone 1 / 21)
 02 = ATEX / IECEx / UKEx (Zone 2 / 22)

Measuring range

1g = 1 g rms
 2g = 2 g rms
 4g = 4 g rms
 6g = 6 g rms
 8g = 8 g rms
 10g = 10 g rms

Frequency range

00 = 10 – 1000 Hz (standard)
 01 = 1 – 1000 Hz

Housing material

00 = 1.4305 (V2A) (standard)
 01 = 1.4404 (V4A)
 50 = 1.4305 (V2A) with adaptation for metal protection hose
 51 = 1.4404 (V4A) with adaptation for metal protection hose

Temperature range

00 = -40°C to 85°C
 01 = -35°C to 125°C
 02 = -20°C to 125°C

Connection

000 = M12 connector (standard)
 020 = 2 m integrated cable
 050 = 5 m integrated cable
 100 = 10 m integrated cable



Don't see your desired configuration listed? Please contact us and we can offer you a solution for your specific needs.

21 EU and UK Declaration of Conformity

Declaration of conformity

HAUBER-Elektronik GmbH
 Fabrikstraße 6
 D-72622 Nürtingen

declares under our sole responsibility that the products listed below that relate to this declaration meet the basic health and safety requirements of the norms and directives below.

Product series

HE200, HE205, HE250, HE250

ATEX Annex

UL International Demko A/S certifies as **Notified Body No. 0539** according to the Directive of the Council of the European Community of 26 February 2014 (2014/34/EU) that the manufacturer maintains a quality assurance system for production that complies with **Annex IV** of this Directive.

UKEx Annex

UL International Demko A/S certifies as **Notified Body No. 0843** according to the UK Legislative Decree 2016:1107 of December 8, 2016, that the manufacturer maintains a production quality system that complies with **Annex IV** of this Legislative Decree.

Affixed CE and UKCA marking



CE 0539 UKCA 0843

Norms and directives



EU Directive	Norms
2014/30/EU / UKSI 2016:1091	EN 61000-6-7:2015 EN 61000-6-3:2007 + A1:2011 EN 61000-6-2:2005-08 EN55011:2016 + A1:2017
2014/34/EU / UKSI 2016:1107	IEC 60079-0:2017 + Corr.1:2020 + I-SH01:2019 + I-SH02:2019 IEC 60079-1:2014 + Corr. 1:2018 + I-SH01:2020 IEC 60079-7:2017 IEC 60079-31:2013
	EN IEC 61000-6-2:2019-02
2011/65/EU / UKSI 2012:3032	

Marking and certificates

HE200.02 / HE205.02 / HE250.02 / HE255.02

Marking	Certificate
 II 3G Ex ec IIC T4 Gc  II 3D Ex tc IIIC 135°C Dc	ATEX: UL 21 ATEX 2570 X UKEx: UL22UKEX2480X

HE200.01 / HE205.01 / HE250.01 / HE255.01

Marking	Certificate
 II 2G Ex db IIC T4 Gb  II 2D Ex tb IIIC 135°C Db	ATEX: UL 20 ATEX 2421 X Rev. 0 UKEx: UL22UKEX2479X

Signature

Nürtingen, 07/11/2022

Place and date



Tobias Bronkal, Managing Owner